

ABN 71 112 123 038

~~EXPORT~~
QUALITY

INSTALLATION AND SERVICE INSTRUCTION MANUAL

For

**GREENPLATE® 300
'INBENCH ELECTRIC BARBECUE'**

Australian Patent # 761137
SAA 172029



Telephone (07) 3245 3008

TECHNICAL SERVICE 0411 845 534

DESIGNED AND MANUFACTURED IN AUSTRALIA

GREENPLATE IS A REGISTERED TRADEMARK OF COSMOS SOLAR PTY LTD

INSTALLATION AND OPERATING INSTRUCTIONS

1. Congratulations on the purchase of your new Greenplate ® electric barbecue, upon arrival inspect the Greenplate ® 300 carefully for concealed damage. Immediately report any damage to your Greenplate ® agent. Remove all packaging and all plastic coating from the stainless steel unit before installation.
2. **Correct wiring of the Greenplate ® Barbecue is essential. Incorrect installation will void the Warranty. Each Greenplate ® barbecue plate must have its own 10 amp circuit with a 20 amp RCBO C-Curve type A. Having a rated residual operating current not exceeding 30mA in the sub-board, as per AS3000.2018 standard requires a minimum of 2.5 mm² cabling for each unit for longer runs larger cabling will be required. If unsure contact Greenplate Pty Ltd service on 0411 845 534. An Australian approved 3 pins, 10 amp electrical lead is supplied with the BBQ. All electrical work must be carried out by appropriated electrical licenced personnel in accordance with the National wiring rules.**
3. **Unit must be installed in a weather proof enclosure to IPX4 or equivalent, minimum 50 mm clearance around electrical housing is required. Please protect barbecue plate and benches from industrial fallout during any construction as rust from filings or chemicals will not be covered under warranty**
4. **Benches not supplied by Greenplate Pty Ltd must be adequately cross ventilated. Ventilate bench to allow free air flow through cabinet. Failure to ventilate the bench can result in premature failure of equipment, this is not covered under warranty. Cross Ventilation area of 0.035m² required. All Greenplate ® benches are pre-fitted with adequate ventilation.**
5. Cut square hole into bench top where desired (490 mm x 490 mm). Carefully lower Greenplate ® 300 BBQ unit into opening. Install hold down U bracket, threaded drain pipe and washers as per (Figure 3.). Position ON/Off push button switch to your desired location (19 mm hole). Mount switch plate, instruction and safety labels to outside of bench. (Note: safety labels are a legal requirement in public spaces).

If bench/cabinet is deeper than the thread of the switch, routing out the back of the bench where switch is to be fitted to 40 mm is required. This will allow the nut to thread onto the back of the switch and for the connection of the switch to the cable.
6. Ensure appropriate grease collection bin and bag (supplied) is placed under the drain tube.
7. Plug BBQ lead into power point having an earth contact (10 amp, 230 VAC) and turn ON (at wall only). Set temperature module to your required temperature, 320°C is recommended, for general use.
8. Switch on mains power, after 5 seconds the BBQ will beep once for thermocouple or twice for thermostat selected. Push the switch to start the BBQ. A buzzer will sound once and the push button switch will light red when BBQ is heating and green when desired cooking temperature is reached. The timer is preset to switch off the barbecue after 28 minutes. To stop barbecue during cycle press and hold the switch for 5 seconds the BBQ will beep 3 times identifying the shutdown end of cooking cycle.
9. A security setting is available by switching the micro switch #1 and #2 on the PCB control board to on position. **This selects the press and hold, for the six seconds delay function, and should be accessed by qualified personnel only.**
10. **Clean the plate prior to use with warm soapy water to remove any dirt and for safe hygienic cooking. Ensure the plate is cleaned regularly to maintain its appearance and longevity. Greenplate also can supply BBQ cleaning kits upon request.**
11. **This appliance is not intended for use by persons (including children) with reduced physical, sensory or mental capabilities, or lack of experience and knowledge, unless they have been given supervision or instruction concerning use of the appliance by a person responsible for their safety. Children should be supervised to ensure that they do not play with the appliance.**
12. **WARNING:** Charcoal or similar combustible fuels must not be used with this appliance

Clean barbecue plate with scraper, scourer, 80 grit wet and dry sand paper. This will in no way damage the plate but care must be taken to ensure no moisture enters the cabinet. **High pressure cleaning is to be avoided as well as sprinkler systems. Water damage is not covered by Warranty.**

Greenplate ® 300 barbecues are designed for years of trouble free and energy efficient service. As for any electrical products used outdoors a six monthly safety inspection should be carried out by qualified personnel only.

All Greenplate ® 300 series barbecues operate at safety extra low voltage of ~26 VAC at 1800 watt. This delivers safe-energy savings for the future.

TROUBLE SHOOTING

Greenplate BBQs are designed with built in trouble shooting codes, some of these codes are re-settable by pushing the switch. If the BBQ does not reset, please contact Greenplate Technical Service.

(IF NO SUCCESS CALL TECHNICAL SERVICE ON 0411 845 534)

Dip Switch Settings	
	➤ # 1 On Only – Normal Press To Start
	➤ # 1 & 2 On – Six Second Delay
	➤ # 1 & 2 Off – Continuous Run
	➤ # 3 On – Thermostat Model Only
	➤ # 3 Off – Thermocouple Model Only

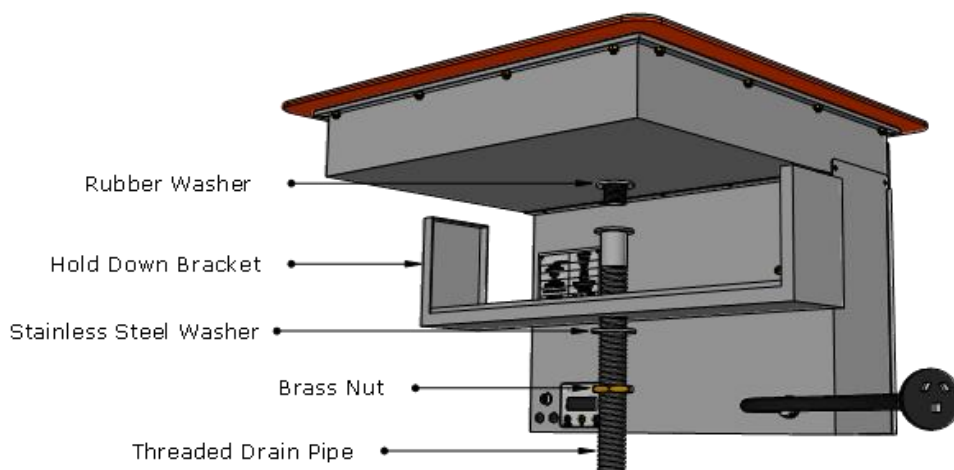
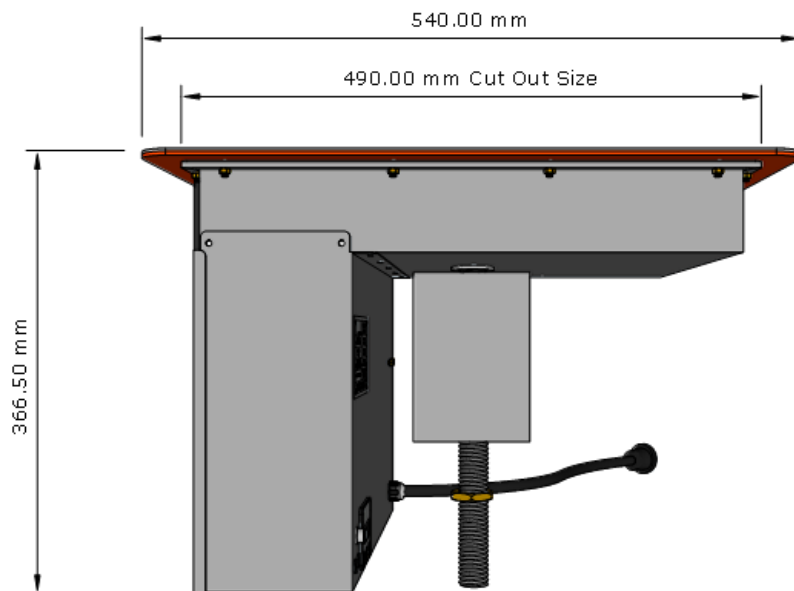
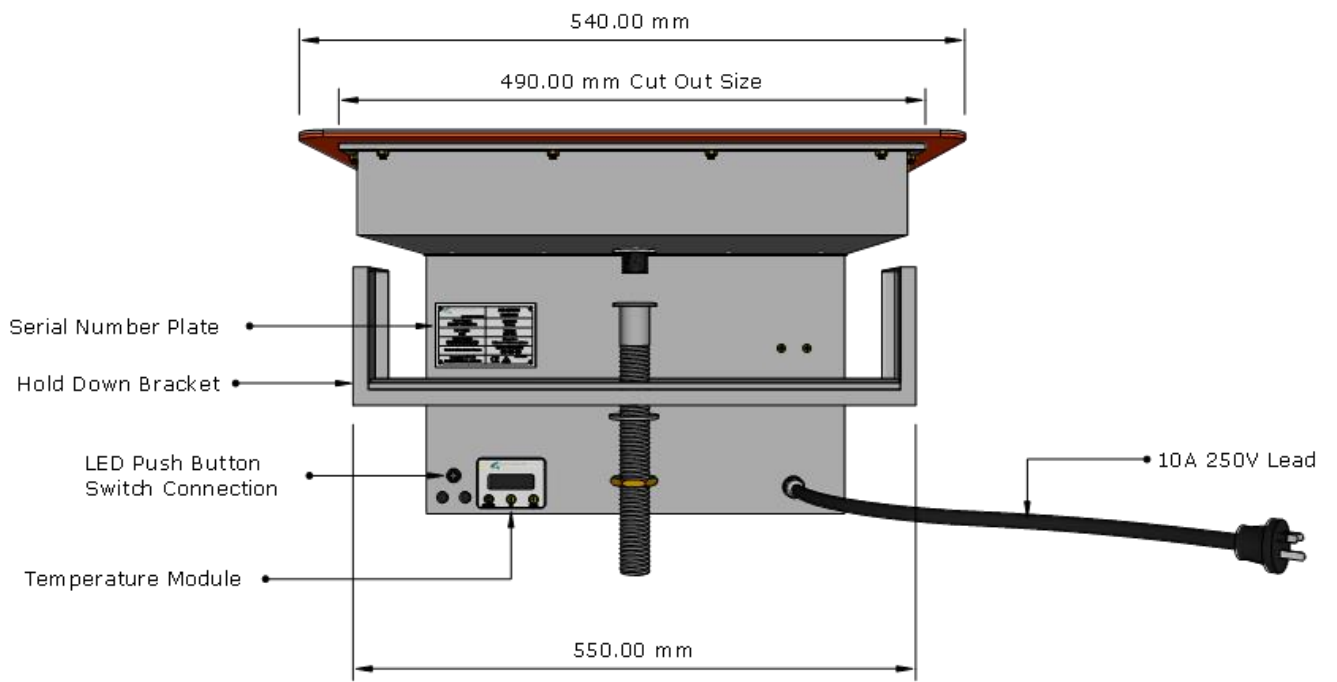

GREENPLATE BBQ PRODUCTS WARRANTY POLICY STATEMENT

Greenplate Pty Ltd warrants all component parts for a period of twenty-four (24) months from the date of purchase from Greenplate's factory. Our warranty covers labour charges for parts replacement for a period of twenty-four (24) months from the date purchased.

Greenplate Pty Ltd will warrant the **Element** for five (5) years from the date of purchase. This warranty will also cover labour charges incurred in replacing the Element for a twenty-four (24) months period from the date of purchase.

Greenplate provides a lifetime limited structural warranty on all Stainless Steel Cabinets and Inbench BBQ units.

Greenplate Pty Ltd warranty does not cover mileage, travelling time or any after hour's charges or costs, unless prior arrangements have been approved in writing.

Telephone Number: + 61 7 3245 3008

Fax Number: + 61 7 3245 3009

Email: info@greenplate.com.au

Procedure to initiate warranty work:

- Advise Greenplate Pty Ltd of the suspected problem, location and serial number.
- Obtain an official order number from Greenplate Pty Ltd.
- Any parts required will be forwarded to you on a Greenplate Pty Ltd invoice.
- The faulty parts are to be returned to Greenplate Pty Ltd within 14 days. Stating the problem, serial number, location and date of purchase details.
- A credit or replacement will be issued upon the receipt of faulty parts.

Please note: All repairs are to be carried out by **Qualified Personnel Only**. Warranty void by unauthorized repairs.

If labour charges are to be covered under warranty by Greenplate the procedure is as follows:

- Contact Greenplate and provide a quotation for the works to be carried out.
- Obtain approval from Greenplate for the works to be carried out by the nominated person or company.
- Provide an invoice to Greenplate on completion of repair.
- Greenplate will arrange payments to be made.

The appliance is to be connected to a socket-outlet having an earthing contact (for class I appliances); The supply cord should be regularly examined for signs of damage and the appliance is not to be used if the cord is damaged. If it is damaged it must be replaced by a special cord assembly available from the manufacture or its service agent.



Caution Hot Surface