

# INBENCH ELECTRIC BBQ UNIT



## KEY FEATURES

- Innovative 24V Heating Element
- Premium 2.5mm 443 Stainless Steel Hot Plate
- Red & Greenplate LED Push Button Switch
- Adjustable Cooking Temperature 50°C - 320°C
- Audible ON/OFF Tones
- 6 Second Hold to Start Child Safety Feature
- Digital Temperature Display and Cycle Counter



## ELECTRICAL INFORMATION

- Power Supply: 200/230VAC |50/60Hz Self Selecting
- Element: 1800 Watts/7.8 Amps
- ESO Approval #: SAA172029
- Patent #: 761137
- Conformant to AS/NZS 60335.1-2011+A1 Standards for General Electrical Appliance Safety

## WARRANTY

- Electrical Components - 2 Years
- Heating Element - 5 Years
- All Stainless Steel Components - Lifetime

All BBQs must be installed on there own separate 20A RCBO with a minimum of 2.5mm cable as per AS3000.2018 Standard.

## Product Dimensions:

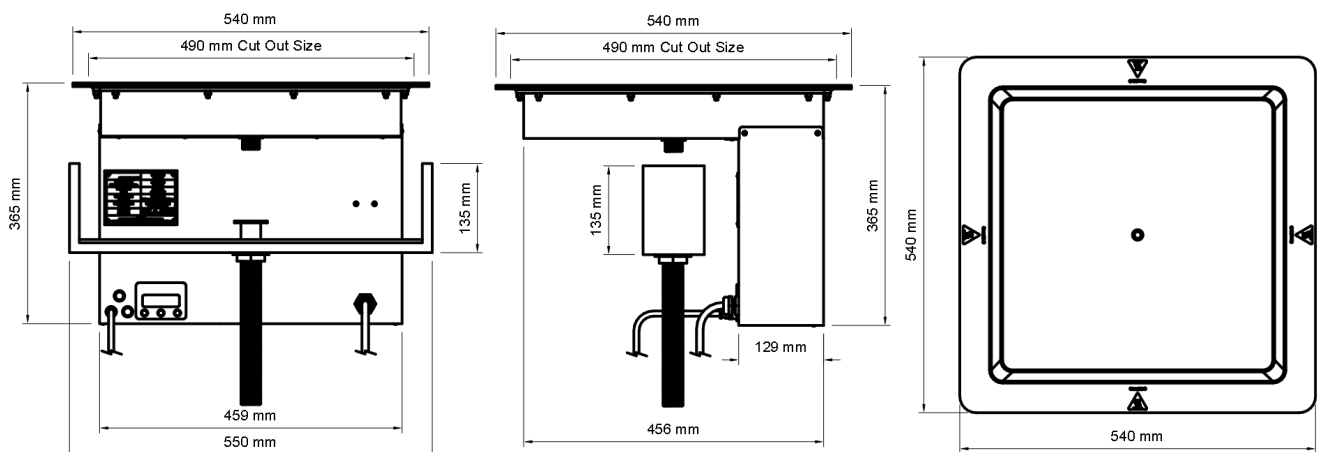

Weight: 42kg

Product Code: 30000

# DC SERIES INBENCH ELECTRIC BBQ



## KEY FEATURES

- Powered By 24VDC Supply
- Innovative 24V Heating Element
- Premium 2.5mm 443 Stainless Steel Hot Plate
- Red & Greenplate LED Push Button Switch
- Adjustable Cooking Temperature 50°C - 320°C
- Audible ON/OFF Tones
- 6 Second Hold to Start Child Safety Feature
- Digital Temperature Display and Cycle Counter



## ELECTRICAL INFORMATION

- Power Supply: 24 VDC (BATTERY)
- Element: 1800 Watts/70 Amps
- 120 Amp Anderson Plug Connection

## WARRANTY

- Electrical Components - 2 Years
- Heating Element - 5 Years
- All Stainless Steel Components - Lifetime

## Product Dimensions:

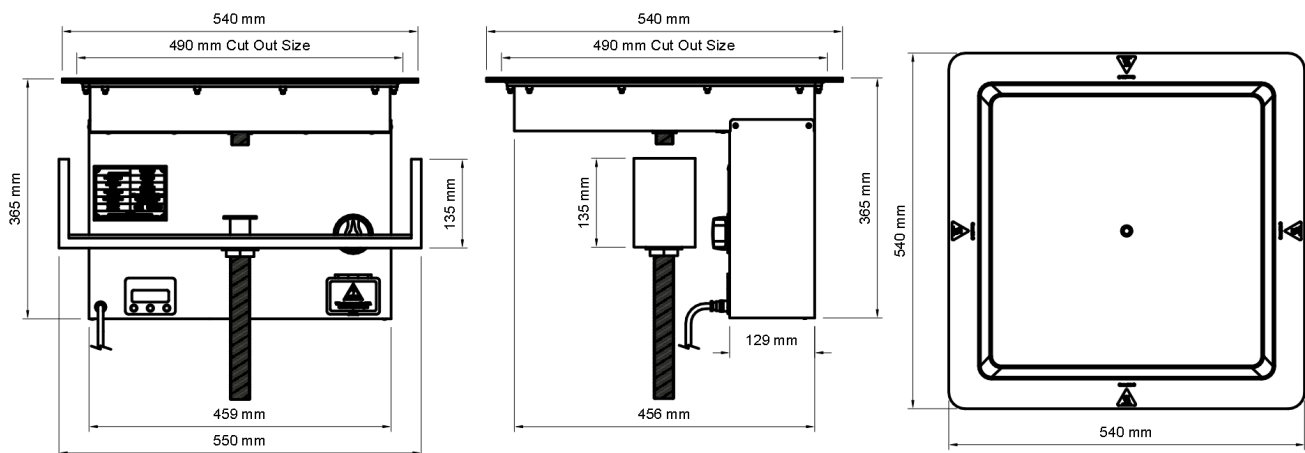

Weight: 25kg

Product Code: 30000DC