

# MATILDA ELECTRIC BBQ CABINET RANGE

## KEY FEATURES

- Red & Green LED Push Button Lighting
- Premium 1.5mm 304 Stainless-Steel Substructure & 2mm Bench Top Construction
- Versatile Configurations
- Equipped with Greenplate's Patented Inbench Electric Barbecues
- Partial Disability Approved

## WARRANTY

- Electrical Components - 2 Years
- Heating Element - 5 Years
- All Stainless Steel Components - Lifetime (Includes BBQ, Substructure and Bench Top - Conditions Apply)



## Optional BBQ & Bench Accesories

### STAINLESS STEEL SINKS



### HINGED BBQ COVER



### BAFFLE TYPE FAT BIN



### ABOVE BENCH HOUSING



### POWDER COATING OPTIONS AVAILABLE P.O.A



## Matilda Electric BBQ Cabinet Range

### MATILDA SINGLE

Weight: 55kg\*  
(Weight Excluding BBQ.  
Add 42kg per BBQ)

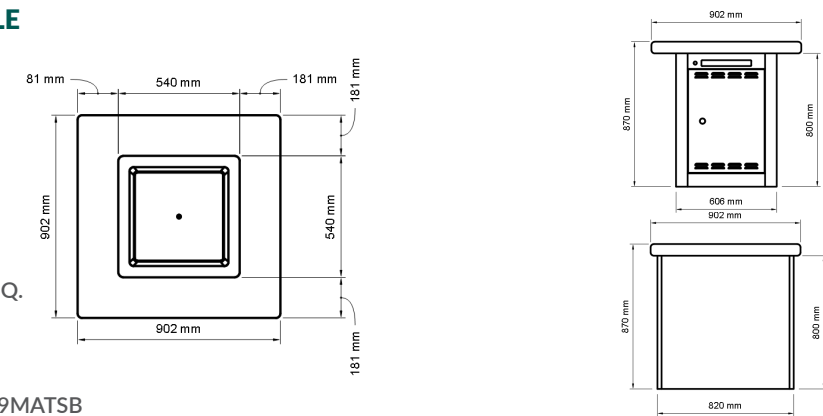

Product Code: 30069MATSB

### MATILDA DOUBLE ONE BBQ

Weight: 80kg\*  
(Weight Excluding BBQ.  
Add 42kg per BBQ)

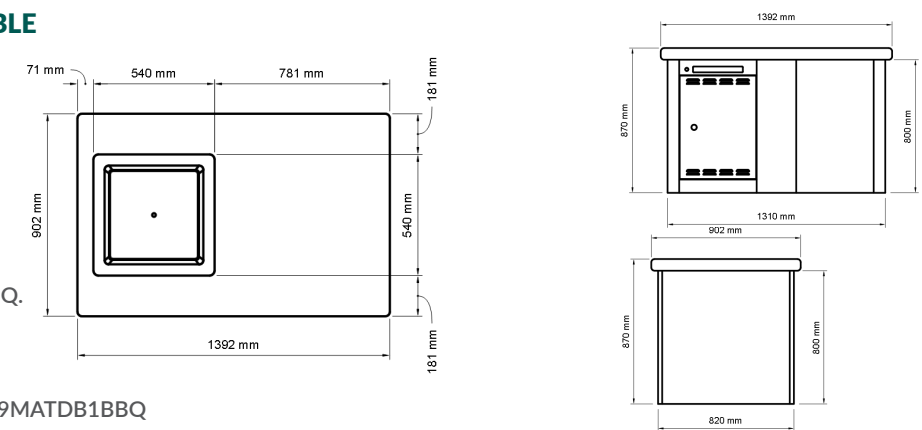

Product Code: 30069MATDB1BBQ

### MATILDA DOUBLE

Weight: 95kg\*  
(Weight Excluding BBQ.  
Add 42kg per BBQ)

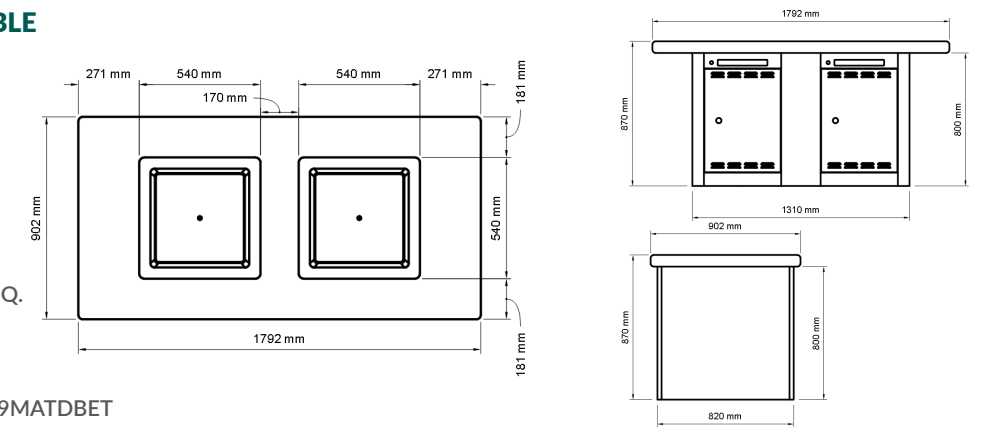

Product Code: 30069MATDBET

### MATILDA TRIPLE

Weight: 170kg\*  
(Weight Excluding BBQ.  
Add 42kg per BBQ)

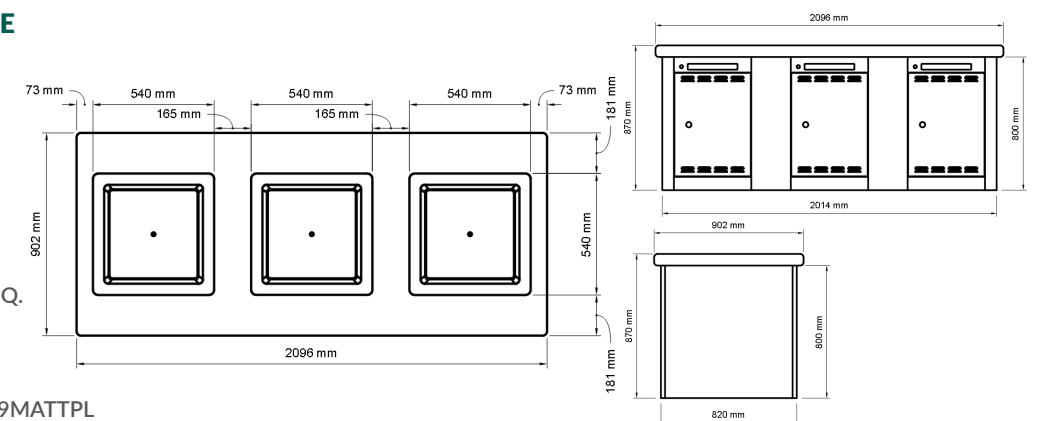

Product Code: 30069MATTPL