

ECO ELECTRIC BBQ CABINET RANGE

KEY FEATURES

- Red & Green LED Push Button Lighting
- Premium 1.5mm Magnesium Aluminium Alloy Coated Steel Substructure & 1.5mm 304 Stainless Steel Bench Top Construction
- Single & Double Configurations
- DDA Certification
- Equipped with Greenplate's Patented Inbench Electric Barbecues

WARRANTY

- Electrical Components - 2 Years
- Heating Element - 5 Years
- All Stainless Steel Components - Lifetime (Includes BBQ and Bench Top - Conditions Apply)
- Magnesium Aluminium Alloy Coated Steel Substructure - 20 years - (Conditions Apply)



Eco Electric BBQ Cabinet Range

ECO SINGLE

Weight: 62kg*
(Weight Excluding BBQ.
Add 42kg per BBQ)

Product Code: 30068ECOS

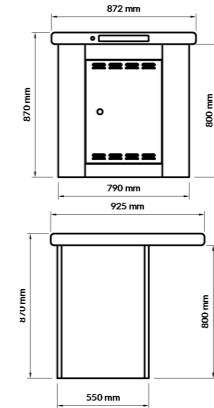
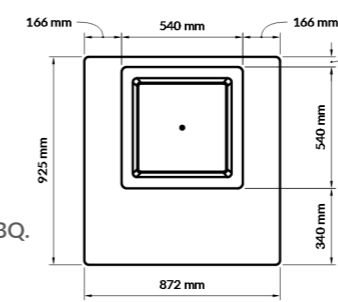

ECO DOUBLE

Weight: 92kg*
(Weight Excluding BBQ.
Add 42kg per BBQ)

Product Code: 30068ECODB

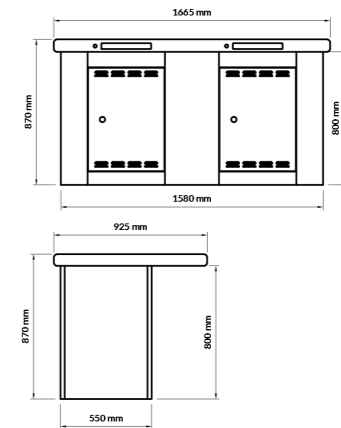
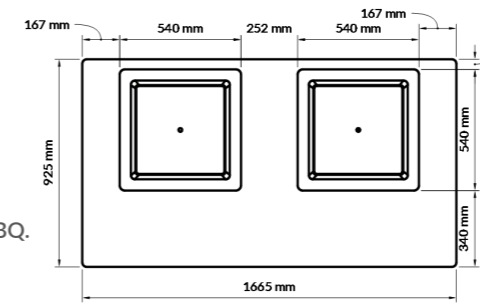

Optional BBQ & Bench Accesories

STAINLESS STEEL SINKS



BAFFLE TYPE FAT BIN



POWDER COATING OPTIONS AVAILABLE P.O.A



HINGED BBQ COVER



ABOVE BENCH HOUSING

